



TransWest Express



The **TransWest Express Transmission Project** is a high-voltage interregional electric transmission system developed by TransWest Express LLC. The TWE Project is critical new infrastructure that will deliver electricity generated by renewable resources and will strengthen the power grid that serves the Western United States. The transmission line begins in south-central Wyoming, has a midpoint terminal in Utah, and ends in southern Nevada.

Delivering renewable energy across the west

The TWE Project will provide the transmission infrastructure and capacity necessary to reliably and cost-effectively facilitate delivery of approximately 20,000 GWh/year of clean and sustainable electric energy generated in Wyoming to Arizona, Utah, Nevada and southern California. Wyoming has a large concentration of high-quality renewable resources in the form of wind energy. The TWE Project will transmit this electric power to the Desert Southwest region where the demand for renewable energy is the greatest.

The TWE Project will:

- Broaden consumers' access to domestic, clean, renewable energy sources.
- Contribute to meeting national, regional and state environmental policies, including state-mandated renewable portfolio standards and greenhouse gas reduction targets.
- Meet increasing customer demand with improved electrical system reliability.
- Provide system flexibility and increased access to the grid for third-party transmission users.
- Expand regional economic development through creating hundreds of jobs and enlarging the property tax base.
- Maintain the standard of living associated with highly reliable electricity service.

Further, multiple third-party studies show the significant economic benefits of tapping Wyoming's high-capacity wind energy to meet a portion of California's renewable energy demand. For example, a 2014 National Renewable Energy Lab economic analysis shows that by sourcing some Wyoming wind, "annual generator cost savings (for California) range from around \$500 million to around \$1 billion." In total, the calculated benefits of a line from California to Wyoming outweigh the costs by more than two times – well above the threshold that utilities typically require before making transmission investments.

Western Area Power Administration, part of the U.S. Department of Energy, is participating in the project. In October 2011, the federal "Rapid Response Team for Transmission" selected the TWE Project for its program to "accelerate responsible and informed deployment" of key transmission facilities.

Project design

The TWE Project has 732 miles of high-voltage transmission infrastructure consisting of two systems: a 525kV direct current (DC) system with terminals near Sinclair, Wyo., and Delta, Utah; and a 500kV alternating current (AC) system from the Utah terminal to southern Nevada. The HVDC system will provide 3,000 MW of

transmission capacity. The HVAC system will be built at 1,500 MW of capacity. The typical right-of-way width for the line is 250 feet. Transmission structure heights may be up to 180 feet depending on structure type, terrain, span and line crossings.

Typical structures

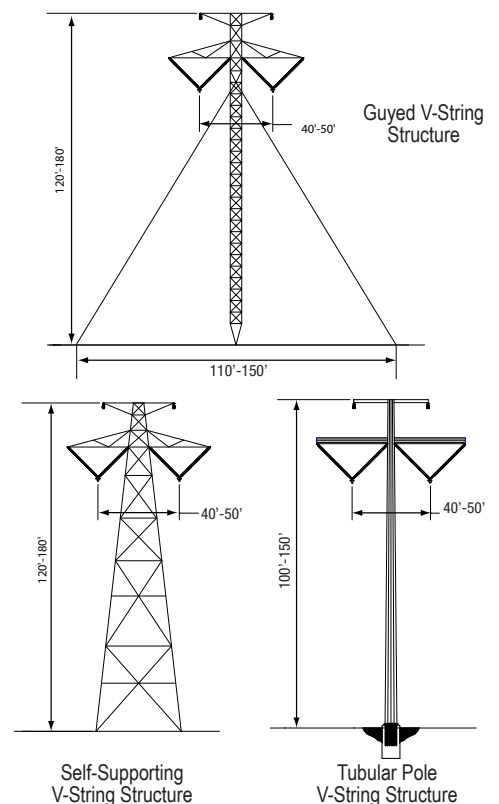

Years of thoughtful planning

TransWest Express LLC conducted a corridor feasibility study to identify the proposed transmission line route and alternative routes, many of which were located within or adjacent to federally designated utility corridors, or parallel existing transmission lines or pipelines.

In 2008, TransWest applied for federal rights-of-way because the proposed route crossed federal land mainly administered by the U.S. Bureau of Land Management and the U.S. Forest Service. The project was considered a major federal action requiring the preparation of an Environmental Impact Statement to meet the requirements of the National Environmental Policy Act. The BLM and Western Area Power Administration were joint lead agencies that prepared the EIS and coordinated with USFS and other federal, state and local government cooperating agencies.

BLM and WAPA sought agency and public input on potential issues to be addressed in the EIS. Based on this input, BLM and WAPA analyzed the proposed route for the transmission line and reasonable alternatives to that route. Public scoping was held January-April 2011. The Draft EIS was announced in July 2013. After addressing comments, the agencies issued their Final EIS in April 2015, identifying their preferred alternative route. The BLM Record of Decision was issued in December 2016, with the WAPA Record of Decision issued in January 2017.

All of the essential federal, state and local permitting decisions and authorizations were complete by early 2023, along with the full acquisition of easements and rights-of-way. The first stage of the TWE Project is expected to be complete in 2027.

About TransWest Express LLC

TransWest Express LLC is a wholly owned affiliate of The Anschutz Corporation, a privately held company based in Denver, Colorado. The Anschutz Corporation, through its affiliates, has been actively involved in the west for over 75 years in the fields of ranching, agriculture and energy development. The Anschutz Corporation's activity and investments in the energy field reflect a strong commitment to responsibly developing and managing natural resources.

TransWest's primary construction partners are Siemens Energy Inc. for the HVDC terminal technology and Barnard Wilson Joint Venture for the transmission line and AC substations. TransWest also is partnering with the International Brotherhood of Electrical Workers and International Union of Operating Engineers.

